

# HYBRID DRIVE SUPER-CAPACITOR ENERGY STORAGE CALCULATION

Pavel Mindl

CVUT FEL - Research Centre of JB, Technická 2, 166 27 Praha 6, Czech Republic

Phone: +420 2 2435 2153

Fax: +420 2 3333 9972

E-mail: [mindl@feld.cvut.cz](mailto:mindl@feld.cvut.cz)

**Abstract.** Presented paper deals with super-capacitor energy storage evaluation. A simple mathematical model for super-capacitor capacitance determination is presented. Results of mathematical calculations are verified on hybrid-drive experimental bench.

**Keywords:** Super-capacitor, energy storage, accumulator, hybrid drive, efficiency of energy conversion.

## 1. INTRODUCTION

Energy storage in vehicle hybrid drives is very serious problem. Traditional solution is based on using of chemical accumulators (lead, nickel-cadmium, Ni-MH, etc.). Nowadays a super-capacitors seems very suitable due to its high-power volume density and high dynamics in charging and discharging. Super-capacitors are namely convenient in a case of car quick velocity changes. Energy accumulated in super-capacitor is for disposal as peak energy for car acceleration. Simple mathematical model for super-capacitor evaluation in hybrid drive for passenger care is derived. Experimental bench for its partial verification is presented.

## 2. ENERGY STORAGE PARAMETERS OVERVIEW

To determine what type of energy storage is suitable for hybrid electric vehicle, analysis of their power and energy density is needed. Following tables present main parameters of classical and non-conventional accumulator types.

Tab.1 Parameters overview of conventional accumulators

Electro-Chemical System	Open circuit emf (V)	Practical specific energy (Wh/kg)	Energy Density (Wh/dm <sup>3</sup> )	Specific Power (W/kg)
Lead Acid	2,1	35	80	200
Ni-Cd	1,35	35	80	260
Ni-Fe	1,4	30	60	100
Ni-H	1,5	55	60	100
Ni-MH	1,35	65	200	200
Ni-Zn	1,73	60	120	300

Tab.2 Parameters overview of non-conventional accumulators

Electro-chemical system	Open circuit emf (V)	Practical specific energy (Wh/kg)	Energy Density (Wh/dm <sup>3</sup> )	Specific Power (W/kg)
<b>Lithium batteries at ambient temperature</b>				
Lithium-ion	4,1	90	200	
Lithium-polymer electrolyte		200	200	160
<b>High temperature batteries</b>				
Li-FeS	1,33	130	220	240 Low (cell)
Li-FeS <sub>2</sub>	1,73	180	350	400 (?)
Na-S	2,08	90-135 100	110-155	130
Zebra	2,58	100	160	150

Comparison of specific energy density (Wh/kg) results for using of lithium accumulators with polymer electrolyte. Although mass power density (W/kg) is relatively sufficient for application in fully electro vehicles. For driving hybrid electro vehicles is possible to have to disposal with respect to energy in fuel relatively small amount of electrical energy. To overcome short distances in electrical regime small chemical accumulator or different type of energy storage can be used. From this point of view a super capacitors for these purposes can be studied. Parameters of high-tech super capacitors are presented in tab.3.

Tab.3 Parameters of high-tech super capacitors and classical chemical capacitors

	Super capacitor	Classical chemical capacitors
Volume specific power [kW/dm <sup>3</sup> ]	100	150
Specific power [kW/kg]	50	100
Volume specific energy [kJ/dm <sup>3</sup> ]	20	1,3
Specific energy [kJ/kg]	10	1
Working temperature range [oC]	-40 až 100	-40 až 100
Working cycles	> 200 000	unlimited

Tab.4 compares specific energy and specific power of lithium-ion battery and super capacitor. In hybrid electric vehicles, where high peak power of super capacitor is very convenient for short-time driving operations a super capacitor is a good solution because of quick charging and discharging.

Tab.4 Comparison of specific energy and specific power stored in lithium-ion battery and super capacitor

	Specific energy [Wh/kg]	Specific power [W/kg]
Lithium-ion battery Lithium-polymer electrolyte	200	160
Super capacitor	6	50k

### 3. KINEMATIC MODEL OF CAR ACCELERATION

Car movement is illustrated by means of velocity versus time (v-t) graph presented in fig.1. Linear car velocity increasing in time interval  $t_1$  and  $t_2$  is assumed. Similar car velocity decreasing in time interval  $t_2$  and  $t_3$  is linear to. Before time  $t_1$  and after time  $t_3$  the car moves with constant velocity and energy for its movement is obtained from internal combustion engine (ICE) or from fuel cells (FC).

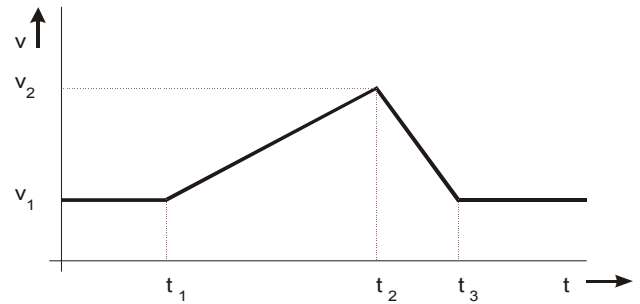

Fig.1 Car acceleration and deceleration expressed by v-t graph

Car trajectory in time interval from  $t_1$  to  $t_3$  is generally

expressed by formula  $s = \int_{t_1}^{t_3} v dt$

In sub-interval  $\Delta t_1 = t_2 - t_1$  car accelerates with acceleration  $a_1$  and passes course  $s_1$  and in sub-interval  $\Delta t_2 = t_3 - t_2$  car decelerates with deceleration  $a_2$  and passes course  $s_2$ .

$$a_1 = \frac{v_2 - v_1}{t_2 - t_1} \qquad a_2 = \frac{v_1 - v_2}{t_3 - t_2}$$

With respect to velocity linear increasing and decreasing it is possible to express acceleration and deceleration by formulas and courses passed by car during accelerating and decelerating intervals are

$$s_1 = \frac{1}{2} a_1 \Delta t_1^2 \qquad s_2 = \frac{1}{2} a_2 \Delta t_2^2$$

Needed accelerating  $F_a$  and decelerating  $F_d$  forces and corresponding energies  $W_a, W_d$  are

$$F_a = m a_1 \qquad W_a = F_a s_1$$

$$F_d = m a_2 \qquad W_d = F_d s_2$$

This evaluation neglected losses due to car aerodynamic resistance and friction, which are estimated around 30% of acceleration energy consumption.

### 4. ENERGY STORED IN SUPER-CAPACITOR

Energy in electric field, stored in super-capacitor is given by expression

$$W_{SC} = \frac{1}{2} C U^2$$

which represents total energy accumulated in capacitor. For practical applications it is acceptable discharging on 50% voltage drop from its nominal value. Therefore for

condenser with nominal voltage  $U_2$  decrease on  $U_2/2$  level is acceptable. Therefore super-capacitor energy  $W_{SC}$ , which is under this conditions to disposal, is equal

$$W_{SC} = \frac{1}{2} C (U_2^2 - (\frac{U_2}{2})^2) = \frac{3}{8} C U_2^2$$

and needed capacitance of super-capacitor is

$$C = \frac{8W_{SC}}{3U_2^2}$$

Mean value of accelerating power  $P_a$  is equal

$$P_a = \frac{W_a}{\Delta t_1}$$

## 5. CONSIDERATION OF ENERGY CONVERTER EFFICIENCY AND SAFETY RESERVE

To have energy reserve stored in super-capacitor for safe driving operation and losses in conversion is necessary. Assuming efficiency factor  $\eta = 0,8$  of hybrid drive with electrical power-splitter and additional traction motor block diagram which of is presented on fig.2. and safe reserve 80%. Installed capacitance of super-capacitor is around

$$C_{in} = 2C = \frac{16W_{SC}}{3U_2^2}$$

## 6. NUMERICAL CALCULATIONS

An automobile having a mass 1500 kg is moving with constant velocity  $v_1 = 30 \text{ ms}^{-1}$ . At the time  $t_1 = 0$  it accelerates and after 10 s in time  $t_2$  achieves velocity  $v_2 = 40 \text{ ms}^{-1}$ . During following 5s interval from  $t_2$  to  $t_3$  car decelerates back to velocity  $v_1 = 30 \text{ ms}^{-1}$  (see v-t- graph on fig.1). Using previous evaluating model for acceleration  $a_1$  and deceleration  $a_2$  we achieve:

$$a_1 = \frac{v_2 - v_1}{t_2 - t_1} = \frac{10}{10} = 1 \text{ ms}^{-2}$$

$$a_2 = \frac{v_1 - v_2}{t_3 - t_2} = -\frac{10}{5} = -2 \text{ ms}^{-2}$$

Courses  $s_1$  and  $s_2$  passed by car in time interval since  $t_1$  to  $t_2$  and  $t_2$  to  $t_3$  are

$$s_1 = \frac{1}{2} a_1 \Delta t_1^2 = \frac{1}{2} * 1 * 100 = 50 \text{ m}$$

$$s_2 = \frac{1}{2} a_2 \Delta t_2^2 = \frac{1}{2} * 2 * 25 = 25 \text{ m}$$

Accelerating and decelerating forces and energy are

$$W_a = F_a s_1 = 75000 \text{ J}$$

$$F_d = m a_2 = 1500 * -2 = -3000 \text{ N}$$

$$W_d = F_d s_2 = -3000 * 25 = -75000 \text{ J}$$

$$F_a = m a_1 = 1500 * 1 = 1500 \text{ N}$$

Energy losses due to car aerodynamic resistance and friction, which are estimated around 30% of acceleration energy consumption are  $25 * 10^3 \text{ J}$ .

Total energy  $W_{SC}$  in super-capacitor needed for acceleration is therefore  $1 * 10^5 \text{ J}$ .

Super-capacitor capacitance, which is needed to be installed in car, when initial condenser voltage  $U_2 = 50 \text{ V}$  is

$$C_{in} = 2C = \frac{16W_{SC}}{3U_2^2} = \frac{16 * 10^5}{3 * 50^2} = 213 \text{ F}$$

Presented theoretical results are experimentally verified on the bench which block diagram is on fig.2.

## 7. EXPERIMENTAL BENCH FOR THEORETICAL RESULTS VERIFICATION

Experimental bench represents so-called parallel hybrid drive with electrical power splitter. Internal combustion engine ICE is substituted by asynchronous motor controlled by frequency converter. On the other bench side wheel and traction load is similarly substituted by asynchronous motor controlled by frequency converter with energy recuperation. Traction motor is asynchronous type. Power splitter is special machine with two rotors. One rotor is with permanent magnets second one is with winding and rings. Converters for super-capacitor charging and discharging are adapted for wide range of operational voltage. Actual task is to determine efficiency of energy conversion in the string: power splitter-super-condenser-traction motor.

## 8. MEASUREMENT OF ENERGY TRANSFER EFFICIENCY

For energy transmission efficiency measurement between

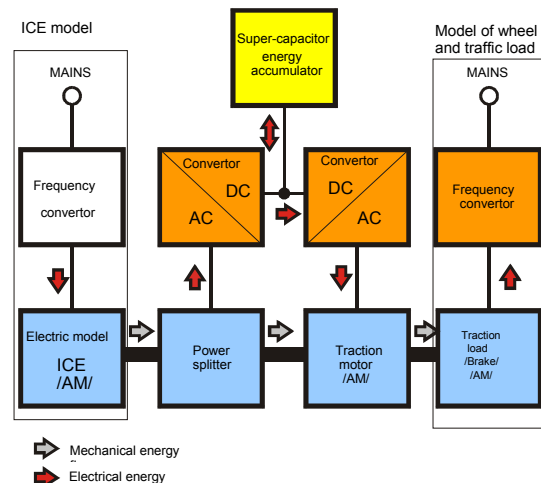

Fig.2 Block diagram of hybrid drive experimental bench Arrangement of hybrid drive with electric power splitter

power splitter and super capacitor and from super capacitor to traction motor special experimental bench is built. Its block diagram is depicted on fig. 3, photo of working bench is on fig 4.

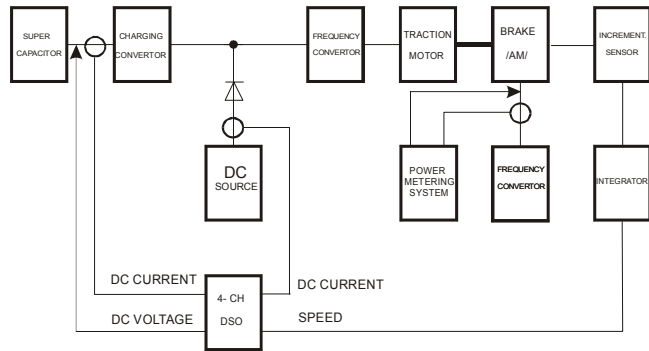

Fig.3 Block diagram of testing bench adapted for measurement of energy transfer from super-condenser to traction motor efficiency



Fig.4 Working stand

## 9. CONCLUSIONS

Application of super capacitors in hybrid electric drives in passenger cars seems to be very realistic. Energy stored in 200 F /56 V seems to be sufficient for car driving manoeuvres or for short courses for instance in traffic jams and etc. In such cases exhaust emissions and fuel consumption can be significantly restricted.

## 10. REFERENCES

- [1] Mindl, P.: Super capacitor for car hybrid drive  
Proceeding of Conference EPO Plzeň  
June 2003
- [2] Robert, J-Remond, B.: What Battery for a Combat  
Electric Vehicle Proceeding of V. International AECV  
Conference, Angers France, June 2003

## AUTHOR



**Pavel Mindl, associated professor.** Since 1982 he teaches in the department of Electric drives and traction, Faculty of Electrical Engineering CTU Prague. His fields of interest are electric apparatus and cars electric and electronic equipment. Except education and research he is oriented on problems and industrial application of low voltage switching and protecting apparatus. On his publication list is more than fifty research reports, journal articles and conference papers.